

Remembering Sandy: Richmond Mar 2019

ROARING JELLY J32 · 3/4L

Hugh Foss: *Glendarroch Scottish Dance Sheets* · Crib: *MiniCrib*s · Diagram: *Keith Rose's Diagrams*

- 1-8 1s cross RH, cast 1 place, cross RH & cast (Man up & Lady down) into centre, 1M between 2s, 1L between 3s
- 9-16 1s+2s+3s circle 6H round & back (1s end in centre)
- 17-24 1s change places RH & dance out of ends to their right, into Figs of 8 (Lady round 2s as 1M dances round 3s)
- 25-32 1s dance reels of 3 on opposite sides giving RSh to 2nd corners & cross RH to places

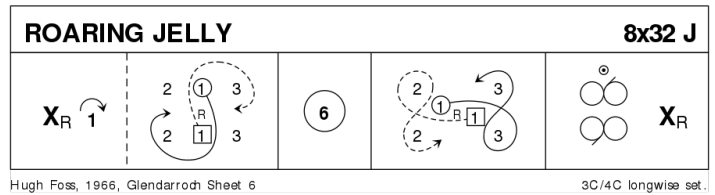

VIDEO: <http://my.strathspey.org/dd/dance/5621/>

CULLA BAY S32 · 4S

Ann Dix: *RSCDS XLI 2* · Crib: *MiniCrib*s · Diagram: *Keith Rose's Diagrams*

- 1-4 1s & 3s advance & 1/2 turn opposite partner RH & cast out to opposite side
- 5-8 1s & 3s chase 1/4 round set cl'wise & dance in passing 2s/4s RSh curving in to face 2s/4s as 2s & 4s repeat bars 1-4 & turn right about to face 1s/3s
- 9-16 All dance parallel reels of 4 across set
- 17-24 2s+1s also 4s+3s circle 4H once round to left, set & dance RH across 1/2 way
- 25-32 2s+4s dance LH across once round, 2s & 4s dance out through sides passing opp partner RSh & chase round set cl'wise to next place

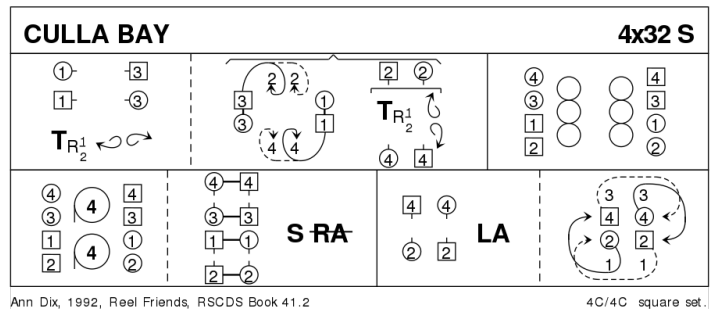

VIDEO: <http://my.strathspey.org/dd/dance/1473/>

DAVY NICK NACK R32 · 3/4L

Robert M Campbell: *Glasgow Assembly And Other Scottish Dances* · Crib: *MiniCrib*s · Diagram: *Keith Rose's Diagrams*

- 1-8 1s+2s+3s cross RH, set, cross back RH & set
- 9-16 1s turn RH 1.1/2 times, cast 1 place & turn LH once to face 1st corners
- 17-24 1s change places RH with corners & set, change places with corner person RH & turn partner LH to face 2nd corners
- 25-32 1s change places RH with corners & set, change places with corner person RH & cross LH with partner to places

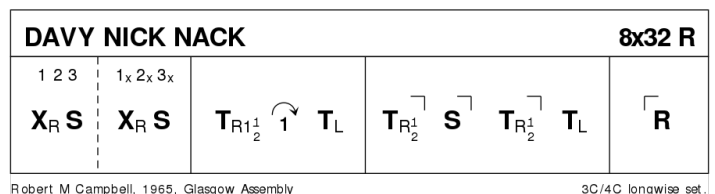

VIDEO: <https://my.strathspey.org/dd/dance/1578/>

BONNIE STRONSHIRAY S32 · 3/4L

Robert M Campbell: Glasgow Assembly And Other Scottish Dances · Crib: MiniCribbs · Diagram: Keith Rose's Diagrams

- 1-8** 1s+2s 3/4 turn 2H to form line up/down centre & dance 1/2 reel of 4, 3/4 turn partners 2H to own sides (having changed places)
- 9-16** 1s set adv to ptrn & turn 1st corner 2H ending 1L between 2s & 1M between 3s, 1s set adv to partner & turn 2nd crnr 2H ending 2nd place opp sides
- 17-24** 2s+1s+3s cross RH & 1s cast to right round 3rd corner (pstns) **while** corners turn right about & Adv+Ret (on diagonal), 2s+1s+3s cross RH (up/down set), 1s cast to right round 4th corner (pstns) & in to face them as 2s+3s turn right about & Adv+Ret
- 25-32** 1s dance 1/2 RSh reel of 4 with 4th corner (pstns), pass LSh & dance 1/2 reel with 3rd corner (pstns) & turn RH back to place

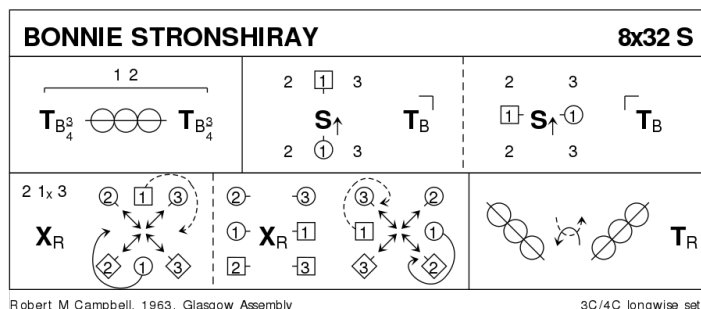

VIDEO: <http://my.strathspey.org/dd/dance/674/>

IAN POWRIE'S FAREWELL TO AUCHTERARDER J128 · 4S

Bill Hamilton: 90 - Twelve anniversary dances celebrating ninety years of RSCDS Edinburgh Branch 13 · Crib: MiniCribbs · Diagram: Keith Rose's Diagrams

- 1-8** All circle 8H round to the left & back (popular variation - 8 hands all the way round to left)
- 9-24** Ladies dance in front of ptrn & behind next Man, into RH across, in front of Man opp own ptrn & behind next Man, into RH across & back to place
- 25-32** All Promenade clockwise
- 33-40** 1s & 3s dance cl'wise behind next couple & Men dance past cpl as Ladies dance in between cpl & both turn R to face cpl, all set & turn RH
- 41-48** All dance parallel reels of 4
- 49-56** 1s & 3s dance a full Fig of 8 round the standing 2s/4s
- 57-64** 1s & 3s dance LH across, 1s & 3s dance back to places (Men round & Ladies through the standing 2s & 4s)
- 65-96** 2s & 4s repeat 33-64
- 97-104** All Promenade anticlockwise
- 105-120** Men dance in front of ptrn & behind next Lady, into LH across, dance in front of Lady opp own partner & behind next L into LH across & back to pl
- 121-128** All circle 8H round to the right & back (popular variation - 8 hands all the way round to right)

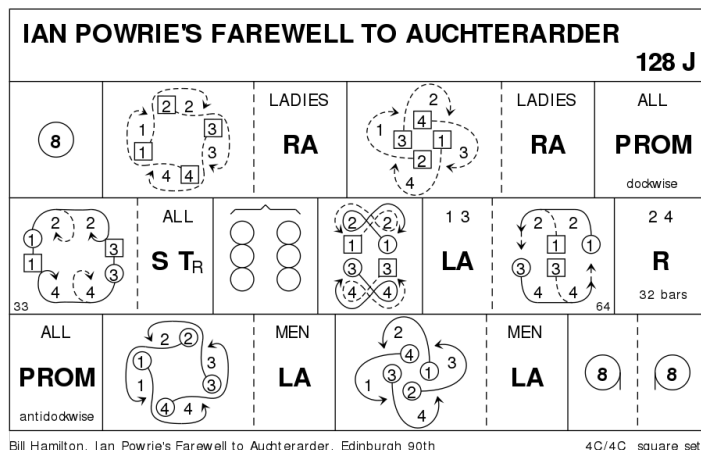

VIDEO: <http://my.strathspey.org/dd/dance/3057/>

SHIFTIN' BOBBINS R32 · 3/4L

Roy Clowes: Ormskirk Scottish Dances - Memorial Edition · Crib: MiniCribs · Diagram: Keith Rose's Diagrams

- 1-8 1s cross RH to double triangle position with 2s+3s & set, 1s cast up to top & dance down until they are between 2s & 3s
- 9-16 1L dances RH across with 2M+3M **while** 1M dances LH across with 2L+3L, 1s followed by 2s+3s dance down centre
- 17-24 3s followed by 2s+1s dance up & 3s+2s cast down to places, 1L dances LH across with 2M+3M **while** 1M dances RH across with 2L+3L
- 25-32 1s dance up to top & cast down to 2nd place opposite side, 1s dance 1/2 Fig of 8 around 2s to end in 2nd place on own sides

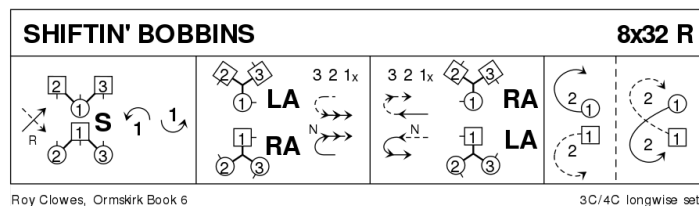

VIDEO: <http://my.strathspey.org/dd/dance/6048/>

THE WIND ON LOCH FYNE S32 · 3T

John Bowie Dickson: Dunedin Dances Book 1 · Crib: MiniCribs · Diagram: Keith Rose's Diagrams

- 1-8 1s cross over (Man between 3s, Lady between 2s) & dance Fig of 8 & end turning RH 1/2 way to face partner in original places
- 9-16 All dance interlocking RSh reels of 4 & end by turning RH to bring Men into centre
- 17-24 Men dance LH across in centre 2 places **while** Ladies dance clockwise 1 place, turn partner RH & repeat ending in triangular set order 2 3 1
- 25-32 All set & circle 6H round for 2 steps, turn partner 2H & continue to circle 6H round to pstns. 2 3 1

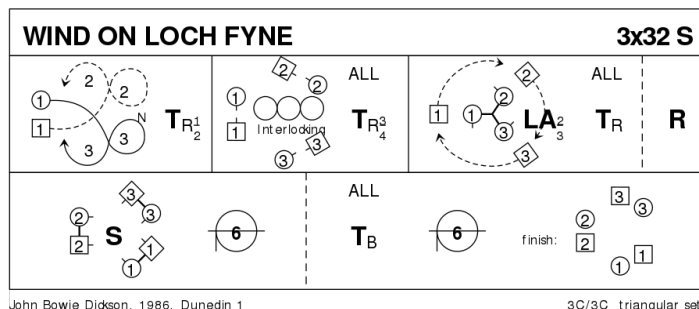

VIDEO: <http://my.strathspey.org/dd/dance/7180/>

CRYSTAL CONGRATULATIONS

R40 · 3/4L

Moira Turner: World Wide Weavings · Crib: E-cribs · Diagram: Keith Rose's Diagrams

- 1-- 1c cross down (2c up) | 1c cast cclw (M up, W down) round 2c+3c to face 1cnr with LHJ
- 9-- 1c+1cnrs set, 1c also turning LH ¼ | 1c turn 1cnrs RH ½ ; ½ diag. Reel4, the cnrs passing Lsh to start, 1c finish in 3cnr positions and 1cnr(persons) finish LHJ facing 2cnr positions on opposite side
- 17-- All cnr persons repeat [9-16] on 2diag., 2cnr(persons) finish LHJ facing 1cnr positions on own side
- 25-- 2cnr(persons)+1c repeat [9-16], 1c finish in the middle
- 33-- 1c turn LH ¾ to 2pl **while{2}** all cnr persons chase clw one place (2,1,3) | All set : 1c dance up and cast off to (2,1,3)

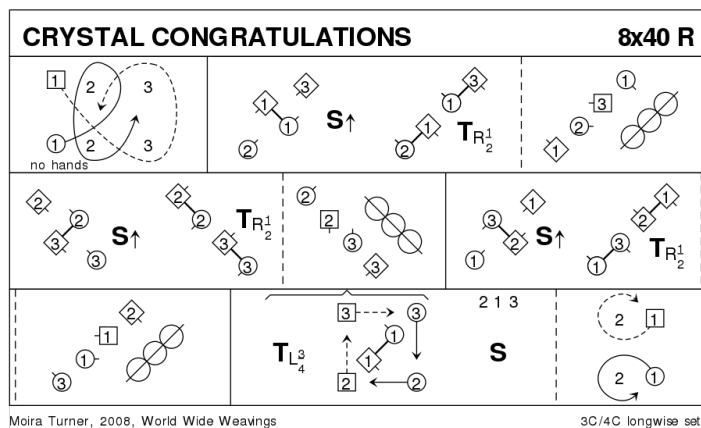

INTERVAL

THE FLIGHT OF THE FALCON

J32 · 3/4L

Barry Priddey: Anniversary Tensome · Crib: MiniCribs · Diagram: Keith Rose's Diagrams

- 1-8 1s set, cast 1 place & turn LH to 1M facing his 1st corner with his partner behind him
- 9-16 1M followed by partner dance a full RSh diagonal Alternating Tandem reel of 3 with 1st corners & end facing Ladies 2nd corner
- 17-24 1M followed by partner dance a RSh Alternating Tandem reel of 3 with 2nd corners & 1s end facing own 1st corners
- 25-32 1s turn 1st corners RH, pass RSh, turn 2nd corner RH & pass RSh to 2nd place own sides (corners turn for 4 bars)

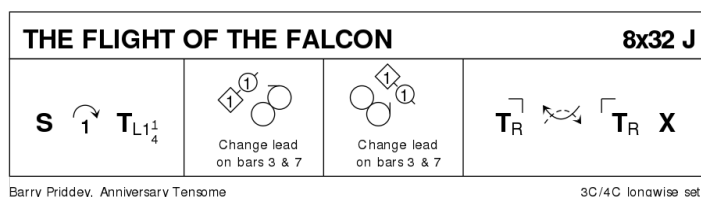

VIDEO: <http://my.strathspey.org/dd/dance/2222/>

MONYMUSK S32 · 3/4L

Preston (18C): RSCDS XI 2 · Crib: MiniCribs · Diagram: Keith Rose's Diagrams

- 1-8** 1s turn RH & cast to 2nd place, turn 1.1/4 times LH to end 1L between 2s to face 1M between 3s
- 9-16** 2s+1s+3s set twice 1s turning (bars 11-12) onto opposite sides & all set twice again on sides
- 17-24** 2s+1s+3s circle 6H round & back
- 25-32** 1s dance reels of 3 on sides giving RSh to person on their Right & 1s cross RH to places

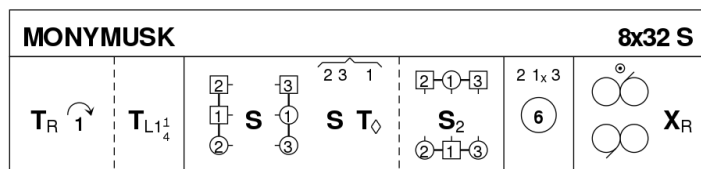

Preston, 1786, RSCDS Book 11.2

3C/4C longwise set.

VIDEO: <http://my.strathspey.org/dd/dance/4646/>

A TRIP TO BAVARIA R32 · 4/4L

James MacGregor-Brown: Collins Pocket Reference: Scottish Country Dancing · Crib: MiniCribs · Diagram: Keith Rose's Diagrams

- 1-4** 1s & 4s cross RH while 2s+3s dance 1/2 RH across, 1s+3s & 2s+4s change places LH on sides
- 5-16** Repeat 1-4 another 3 times (end cpls cross RH, middle cpls 1/2 RH across; cpls in 1st+2nd place also 3rd+4th place change places LH) All finish in original places
- 17-24** 1s set to 2s & cross over to face 3s, set & cross to face 4s
- 25-32** 1s set to 4s & cross over to 4th place on opposite sides, all Adv+Ret 2 steps & 1s change places RH (2H popular) to retire to own sides

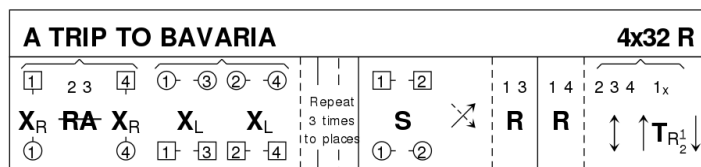

James MacGregor-Brown, Guide to Scottish Country Dancing

4C/4C longwise set.

VIDEO: <http://my.strathspey.org/dd/dance/6712/>

THE SILVERY KNOT S32 · 3/4L

Stella Fogg · Crib: E-cribs · Diagram: Keith Rose's Diagrams

- 1-** 1c lead down {3}, Turn BH {2}, dance up between 3c and behind 2c to places
- 9-** Mirror Reels3 on the sides, 2c starts out and up, take hands when possible (1,2,3)
- 17-** 1c+2c The Knot, 1c finish facing 1cnr
- 25-** 1c set to 1cnr | spiral round P to face 2cnr ; set to 2cnr | spiral to (2,1,3)

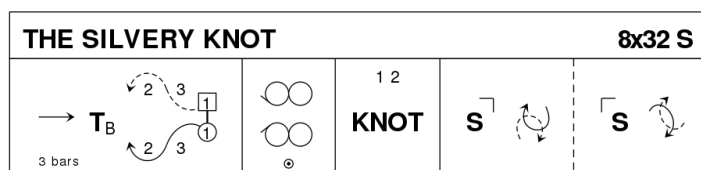

Stella Fogg, 2013

3C/4C longwise set.

THE ELEPHANT'S STAMPEDE J48 · 4S

Lorna Macdonald & Gillian Mackintosh: Aurora 10th Anniversary Book of SCD · Crib: MiniCribbs · Diagram: Keith Rose's Diagrams

- 1-8** All circle 8H round & back
- 9-16** 1s+3s advance & with free hand join with 2s & 4s & retire into longwise set across the dance, all dance 1/2 parallel reels of 4 across
- 17-24** All dance 1/2 R&L at each end of set, turn (person on Mans left) RH 1.1/2 times to form Sq.Set
- 25-32** All Ladies petronella turn to next Ladies place to right & set, repeat to meet partner (all have progressed 1 place to right)
- 33-48** All dance full Schiehallion Reel

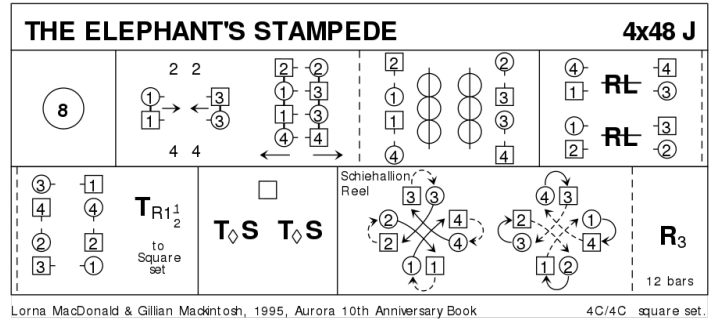

VIDEO: <http://my.strathspey.org/dd/dance/2484/>

MARY ERSKINE R32 · 3/4L

Roy Goldring: A Second Book of Graded Scottish Country Dances · Crib: MiniCribbs · Diagram: Keith Rose's Diagrams

- 1-8** 1s+2s turn on sides 1.1/2 times (Men RH & Ladies LH), 1s cast down behind 3s, meet & dance up to 2nd place facing own sides ready for -
- 9-16** 1s dance Double Triangles & end by turning right about to face each other (remaining in middle)
- 17-24** 1s slip step down centre & back
- 25-32** 1L dances LH across on Men's side as 1M dances RH across on Ladies side & dance 1/2 Fig of 8 round 2s

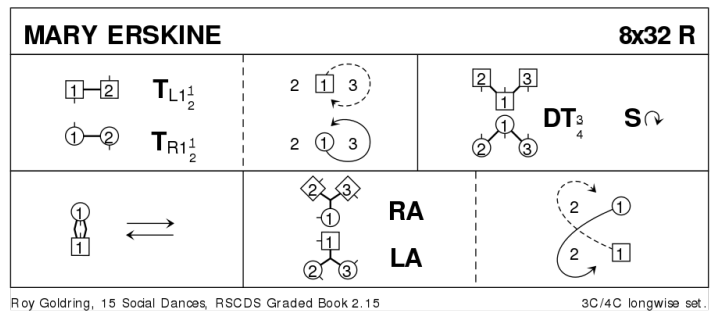

VIDEO: <http://my.strathspey.org/dd/dance/9008/>

GYPSY WEAVER S32 · 3/4L

Denise Peet: Between the Rivers · Crib: MiniCribbs · Diagram: Keith Rose's Diagrams

- 1-8** 1s+3s dance RSh 3/4 round partner to end in line of four in middle (Ladies face down, Men up), 1/2 reel of 4, 1s+3s RSh 3/4 round prtnr to own sides
- 9-16** 2s+1s Set+Link, 3s+1s Set+Link
- 17-24** 1s+3s+2s 1/2 RSh reel of 3 on own sides, 1L followed by partner casts up 1 pl crossing to opp sides & turning left turns prtnr LH to face 1st crnrs
- 25-32** 1s Pass+Turn with 1st corners & pass RSh to face 2nd corners, Pass+Turn with 2nd corners, 1s ending 2nd place own sides

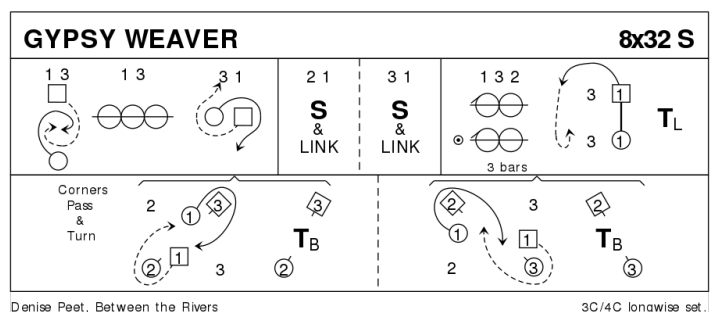

MAIRI'S WEDDING R40 · 3/4L

James B Cosh: Twenty Two SCD · Crib: MiniCribbs · Diagram: Keith Rose's Diagrams

- 1-8 1s turn RH & cast to 2nd place, 1s turn LH to face 1st corners
- 9-16 1s dance 1/2 diagonal reel of 4 with 1st corners, 1s dance 1/2 diagonal reel with 2nd corners
- 17-24 1s dance 1/2 diagonal reel with 3rd corner (pstns), 1/2 diagonal reel with 4th corner (pstns)
- 25-32 1s dance reel of 3 across (Lady with 2s, Man with 3s - LSh to 1st corner)
- 33-40 2s+1s+3s circle 6H round & back

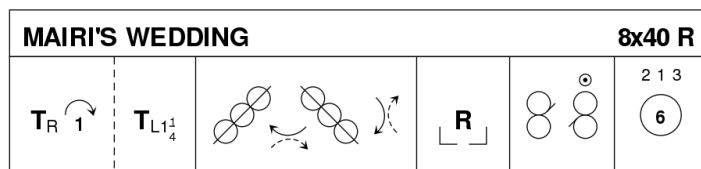

James Cosh, 1959, 22 SCD & 1 other

3C/4C longwise set.

VIDEO: <http://my.strathspey.org/dd/dance/4102/>

FIFTY YEARS TOGETHER W48 · 2/4L

Moira Turner · Crib: E-cribs · Diagram: Keith Rose's Diagrams

There should be no extra space between sets in a line.

- 1- 1c+2c join hands in circle, balance forward and backward. All petronella one place cclw in circle ; repeat (2x, 1x)
- 9- 2c+1c face P RHJ and balance F&B | All cross making arch, W dancing under arch and passing in front of M turning her back to him ; 2c+1c RHA (2,1)
- 17- 1c dance down ; dance Rsh round P 1½ and face up
- 25- 1c dance up to 1plx and face out **while{4}** 2c long cast to (1x,2) ; 1M+2W & 1W+2M dance "easy shoulder" round each other 1½ times, and 2c face out (2,1x)
- 33- 2c+1c DbIFig8 (2,1x)
- 41- 1c ½ Fig8 round standing couple below ; 1c+standing couple below Circle4 L (2,1) and keep hands in circle with this new 2c for the repeat

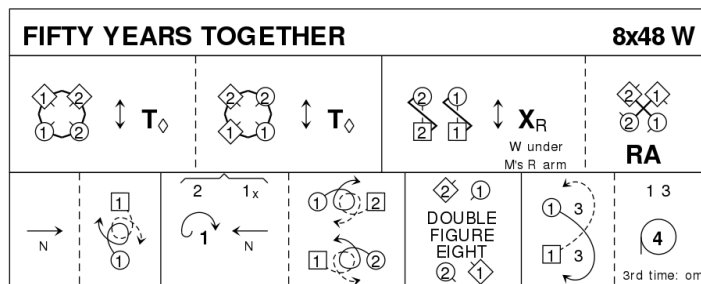

Moira Turner, 2007

2C/4C longwise set.

1c omits [45-48] when at the bottom of the set.